

Air-Cooled Robotic Torches

TOKINARC®
TOKIN CORPORATION

■ ACC-308RR/RX ■ TK Series ■ SRCT-308R ■ DSRC-3531
■ YMXA/YMSA Series ■ YMES Series



www.tokinarc.co.jp

TOKIN CORPORATION

Superb!



ACC-308RR-N

High Accuracy Robotic Torch (*Patented)

- Torch does not bend from collision with workpiece or jig, thus no teaching corrections are needed.

Impact resistance is now nearly tripled by a special copper alloy. Superb dimensional accuracy shortens the time needed for torch replacement.

Torch Model	ACC-308RR-N	
Rated Current (CO ₂)	A	350
Rated Current (MAG)	A	300
Duty Cycle	%	60
Applicable Wire Size	mm	0.8-1.2
	X	264.3±0.3
	Y	116.5±0.4
	θ	35° ±0.3
Cooling Method		Air-Cooled
Cable Length	m	0.8-5

■ ACC Model Notation

ACC-308RR - 1.5

Torch Type

Cable Length

ACC-308RR - N - 0.9

Torch Type

Connection Type

(See page 9.)

ACC-308RR-N

[Parts Drawings]

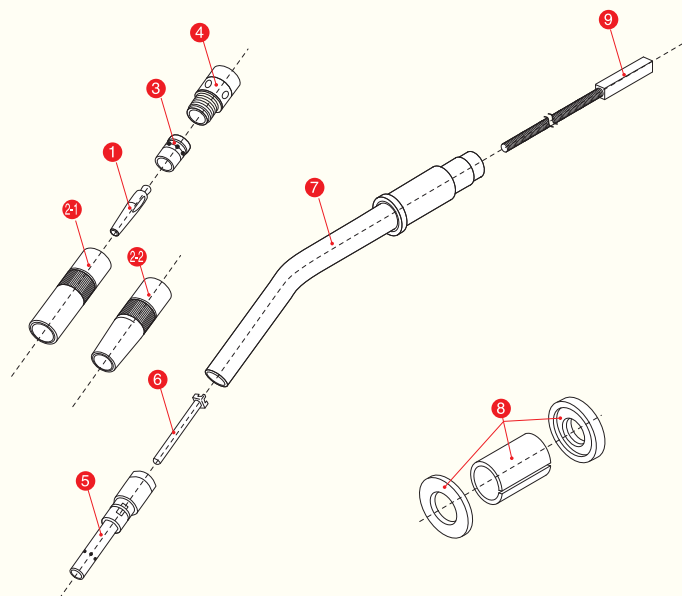

Reference No.	Parts No.	Parts Name
1~15	RA3RN0090	ACC-308RR-N-0.9
	RA3RN0100	ACC-308RR-N-1.0
	RA3RN0110	ACC-308RR-N-1.1
	RA3RN0120	ACC-308RR-N-1.2
	RA3RN0130	ACC-308RR-N-1.3
1	002001	N Tip 0.9 mm
	002002	N Tip 1.0 mm
	002003	N Tip 1.2 mm
2-1	001002	N Nozzle 16 mm
2-2	001003	N Nozzle 12 mm
3	003002	N Orifice S
4	004002	N Insulator S
5	016503	ACC-308RR Tip Body
6	016504	ACC-308RR Guide Tube
7	016501	ACC-308RR Torch Body (w/o Tip Body)
5~7	016500	ACC-308RR Torch Body (w/Tip Body)
8	016052	TK-308RR Insulation Collar
9	016505	ACC-308RR Inner Tube
1~9	016506	ACC-308RR Torch Body Assy



TK-308RR-N

Standard Model Robotic Torch

Torch Model	TK-308RR/S	
Rated Current (CO ₂)	A	350
Rated Current (MAG)	A	300
Duty Cycle	%	60
Applicable Wire Size	mm	0.8-1.2
Cooling Method		Air-Cooled
Cable Length	m	0.8-5

TK-308RS



TK-308RR Model Notation

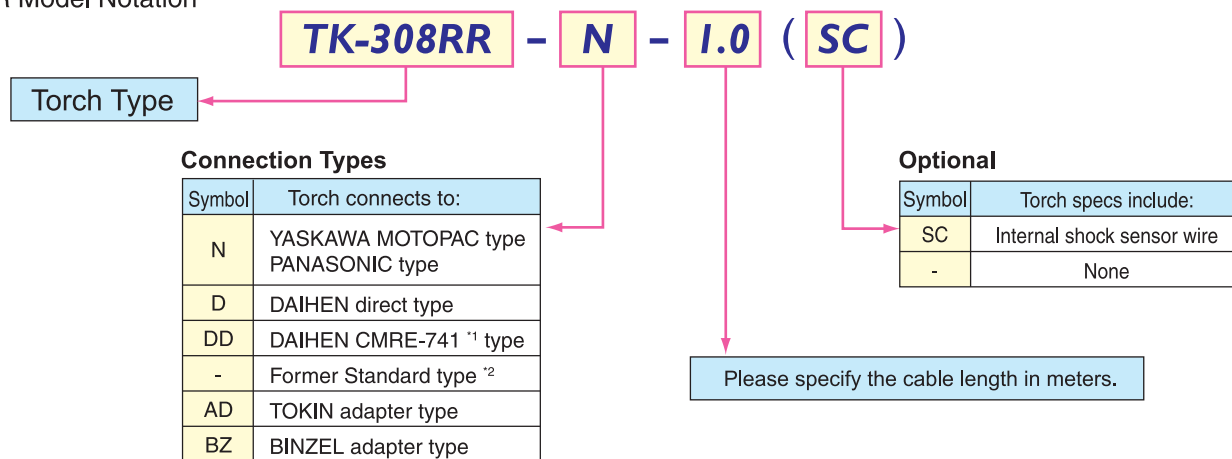

^{*1} Please inform us when using DL350 auto welder.
^{*2} A special adaptor is required when using the former standard type.

Torch body (straight section) of TK-308RR is available in various lengths as shown below. We also accept special orders for fabricating original torch bodies in different lengths of your choice.

Dimensional comparison of TK-308RR (Made-to-order)

Parts No.	Parts Name
016058	TK-308RR Torch Body Assy
016160	TK-308RR Torch Body Assy (+100)
016163	TK-308RR Torch Body Assy (+110)
016166	TK-308RR Torch Body Assy (+150)

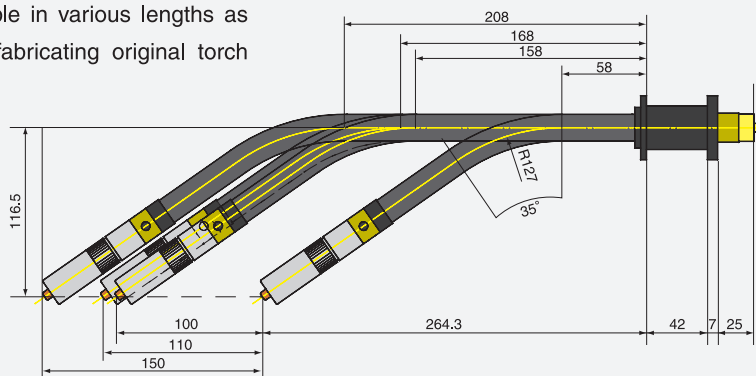

SRCT-308R/307R

Built-in Shock Sensor Robotic Torch

Torch Model	SRCT308R	
Rated Current (CO ₂)	A	350
Rated Current (MAG)	A	300
Duty Cycle	%	60
Applicable Wire Size	mm	0.8-1.2
Cooling Method		Air-Cooled
Cable Length	m	0.8-5

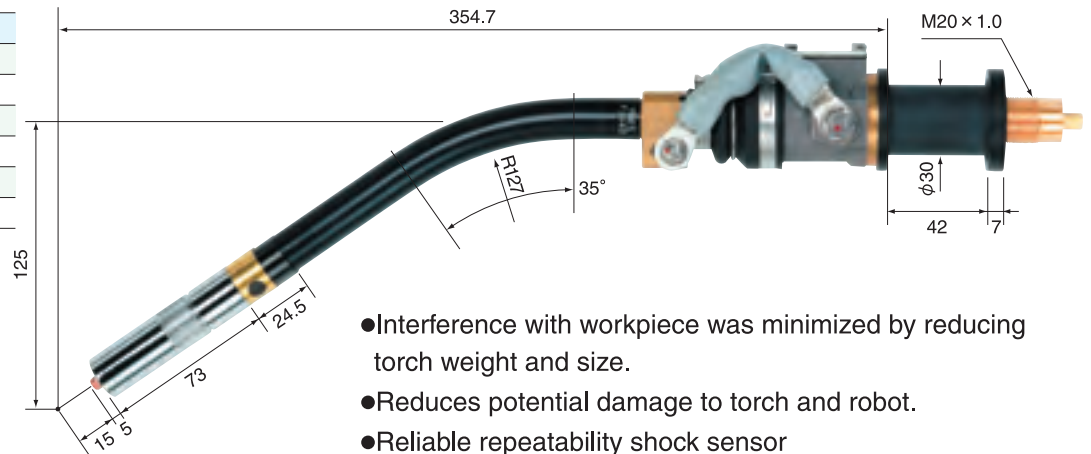

- Interference with workpiece was minimized by reducing torch weight and size.
- Reduces potential damage to torch and robot.
- Reliable repeatability shock sensor
- Without losing a control point, the torch (TK-308RR) is replaceable.

ACC-308RX

High Accuracy Detachable Robotic Torch

Torch Model	ACC-308RX	
Rated Current (CO ₂)	A	350
Rated Current (MAG)	A	300
Duty Cycle	%	60
Applicable Wire Size	mm	0.8-1.2
Cooling Method		Air-Cooled
Cable Length	m	0.8-5

- Torch easily detaches into a "Torch Body Assy" and "Clamp Body Assy" to drastically reduce downtime for torch replacement.

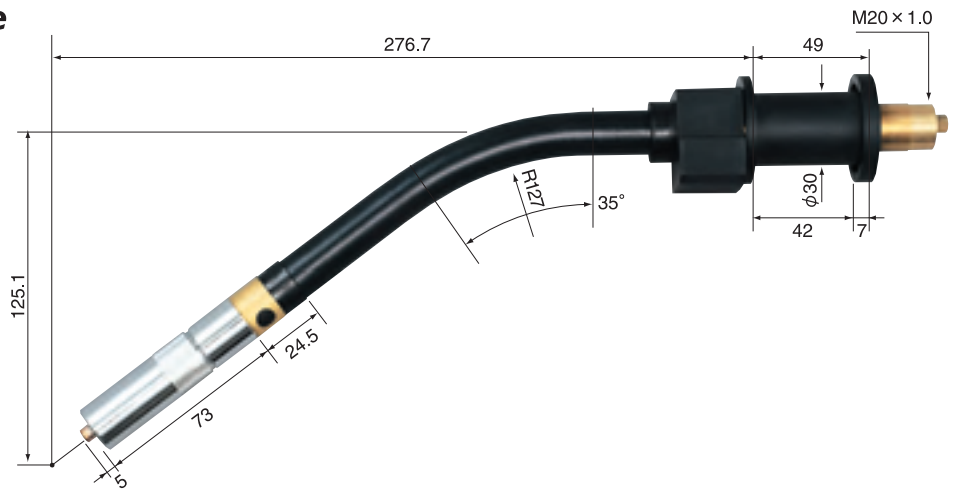

TK-308RX

Torch Body Detachable Robotic Torch

Torch Model	TK-308RX	
Rated Current (CO ₂)	A	350
Rated Current (MAG)	A	300
Duty Cycle	%	60
Applicable Wire Size	mm	0.8-1.2
Cooling Method		Air-Cooled
Cable Length	m	0.8-5

- Torch easily detaches into a "Torch Body Assy" and "Clamp Body Assy" to drastically reduce downtime for torch replacement.
- Positional accuracy of contact tip after torch replacement is ± 0.3 mm.

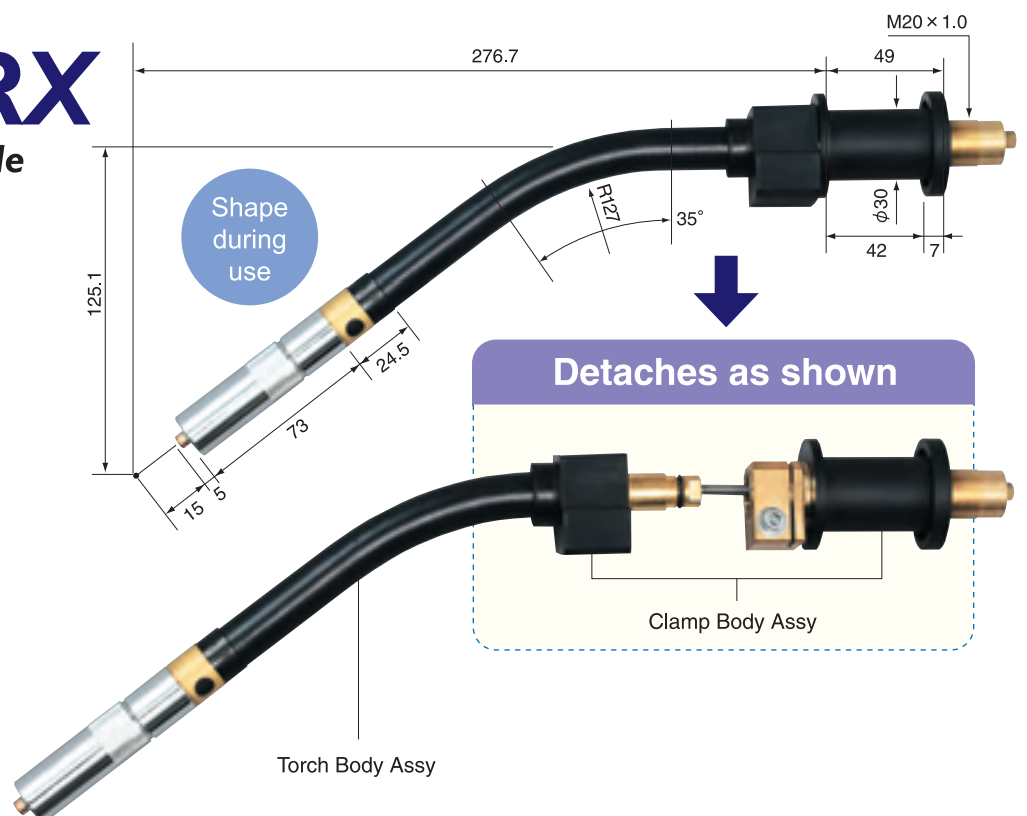

TK-508RR/RX, TK-309R1

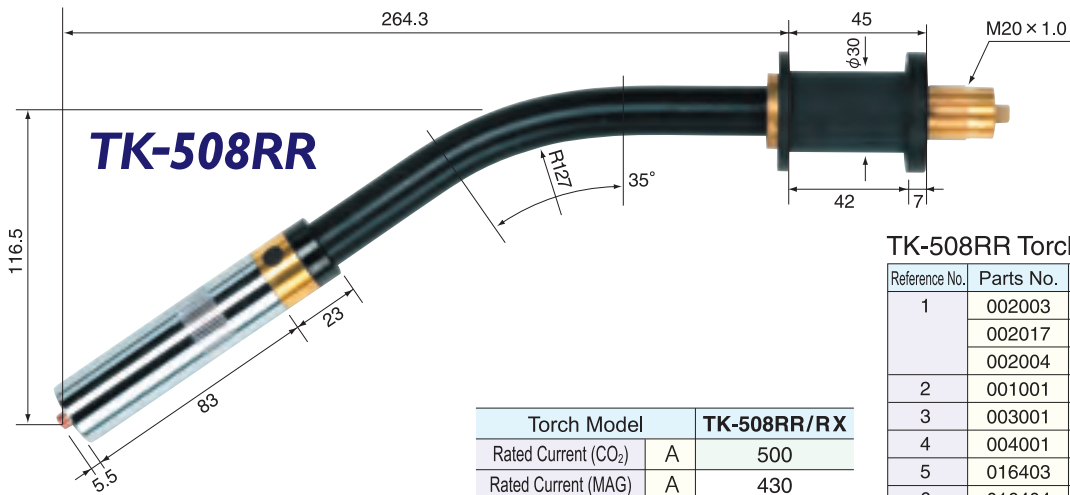

Torch Model	TK-508RR/RX	
Rated Current (CO ₂)	A	500
Rated Current (MAG)	A	430
Duty Cycle	%	60
Applicable Wire Size	mm	1.2-1.6
Cooling Method		Air-Cooled
Cable Length	m	0.8-5

TK-508RR Torch Body Assy Parts List

Reference No.	Parts No.	Parts Name
1	002003	N Tip 1.2 mm
	002017	N Tip 1.4 mm
	002004	N Tip 1.6 mm
2	001001	N Nozzle 19 mm/500 A
3	003001	N Orifice L
4	004001	N Insulator L
5	016403	TK-508RR Tip Body
6	016404	TK-508RR Torch Body (w/o Tip Body)
5+6	016400	TK-508RR Torch Body
7	016052	TK-308RR Insulation Collar
8	016053	TK-308RR Inner Tube
1~8	016401	TK-508RR Torch Body Assy

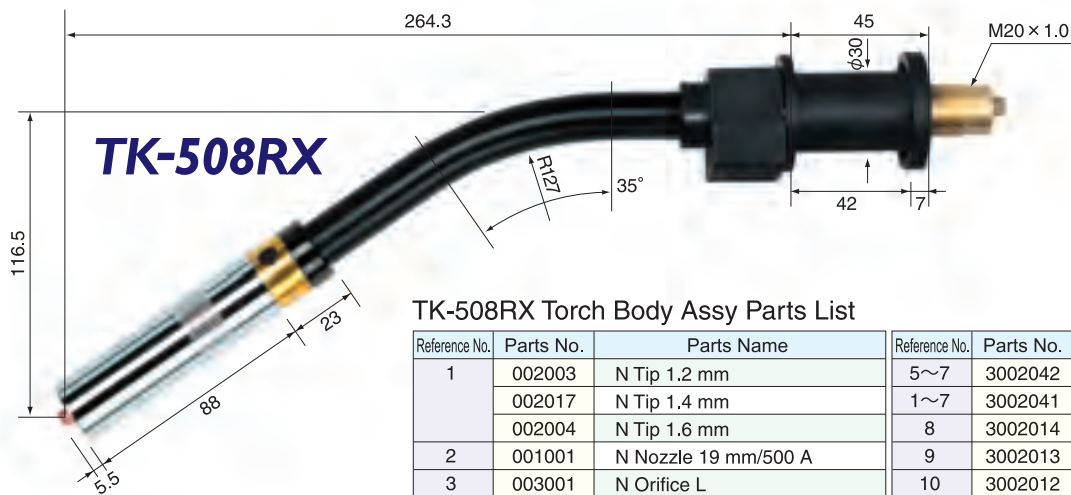

TK-508RX Torch Body Assy Parts List

Reference No.	Parts No.	Parts Name	Reference No.	Parts No.	Parts Name
1	002003	N Tip 1.2 mm	5~7	3002042	TK-508RX Torch Body
	002017	N Tip 1.4 mm	1~7	3002041	TK-508RX Torch Body Assy
	002004	N Tip 1.6 mm	8	3002014	TK-308RX Clamp Block Cover
2	001001	N Nozzle 19 mm/500 A	9	3002013	TK-308RX Clamp Block
3	003001	N Orifice L	10	3002012	TK-308RX Clamp Body
4	004001	N Insulator L	11	016052	TK-308RR Insulation Collar
5	016403	TK-508RR Tip Body	8~11	3002011	TK-308RX Clamp Body Assy
6+7	3002043	TK-508RX Torch Body (w/o Tip Body)	12	016053	TK-308RR Inner Tube
7	Y0000FP10	O Ring F-P10	1~12	3002040	TK-508RX Torch Assy

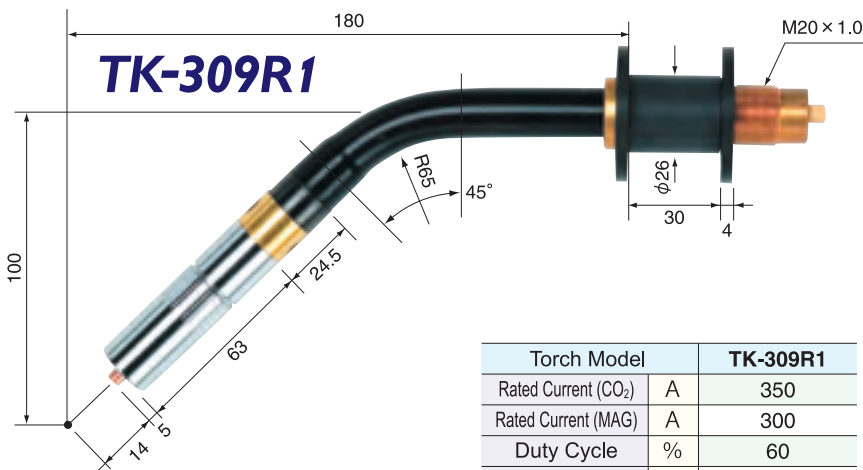

Torch Model	TK-309R1	
Rated Current (CO ₂)	A	350
Rated Current (MAG)	A	300
Duty Cycle	%	60
Applicable Wire Size	mm	0.8-1.2
Cooling Method		Air-Cooled
Cable Length	m	0.8-5

TK-309R1 Torch Body Assy Parts List

Reference No.	Parts No.	Parts Name
1	023008	D Tip 0.9 mm
	023009	D Tip 1.0 mm
	023010	D Tip 1.2 mm
2	001013	N Nozzle 16 mm/63 L/350 A
3	003002	N Orifice S
4	004002	N Insulator S
5	036001	CS Tip Body A
6	016047	TK-309R1 Torch Body (w/o Tip Body)
5+6	016046	TK-309R1 Torch Body
7	016048	TK-309R1 Insulation Collar
8	016053	TK-308RR Inner Tube
1~8	016049	TK-309R1 Torch Body Assy

For All Wire Feeders

POWER CABLES

Cable can be fabricated in all sizes from 0.8 to 5 meters.

308RR-N-1.0 P/C

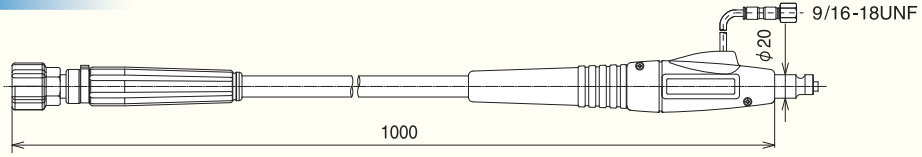

308RR-N-1.0 P/C SC

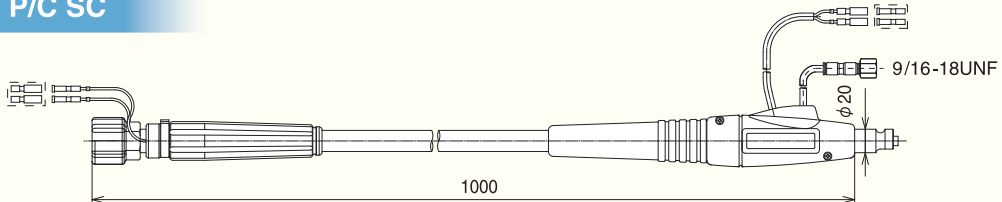

308RR-1.0 P/C

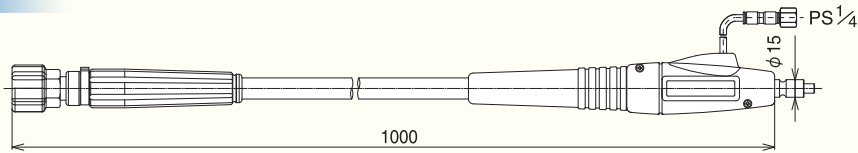

308RR-1.0 P/C SC

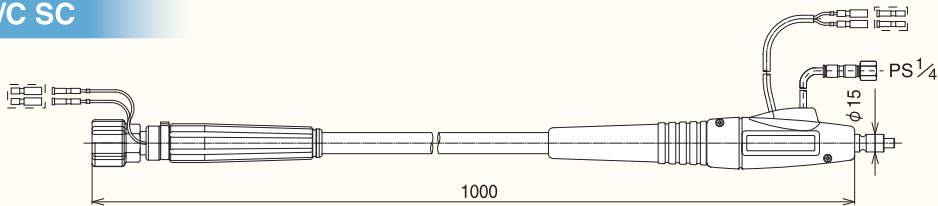

308RR-D-1.0 P/C

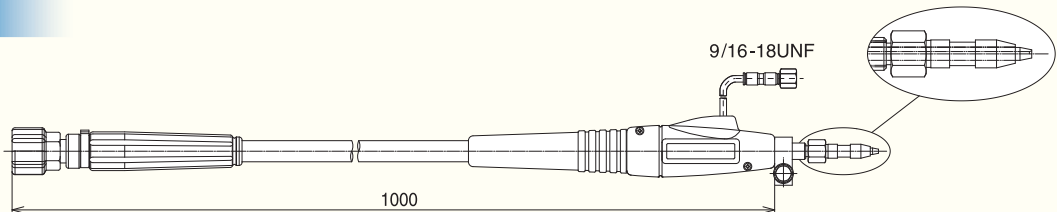

308RR-DD-1.0 P/C (for CMRE-741)

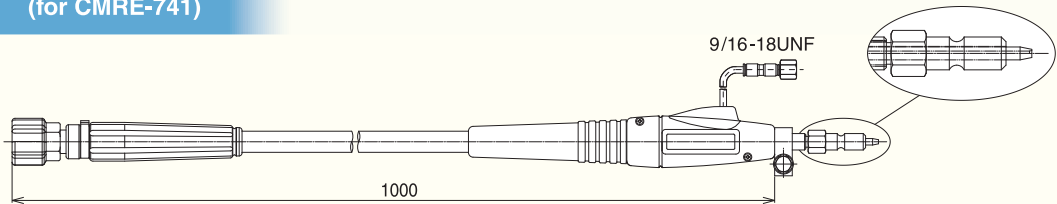

308RR-AD-1.0 P/C

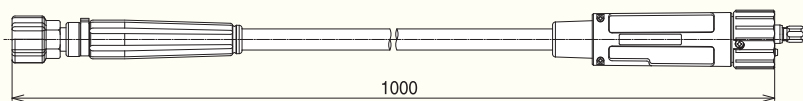

308RR-BZ-1.0 P/C

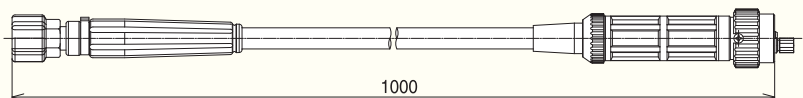

ADAPTERS

308RR Adapter

016080
308RR-T Adapter

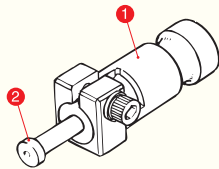

016082
308RR-D Adapter

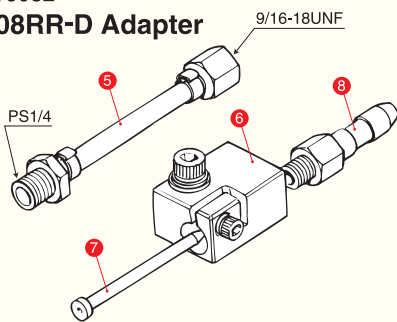

016084
308RR-H Adapter

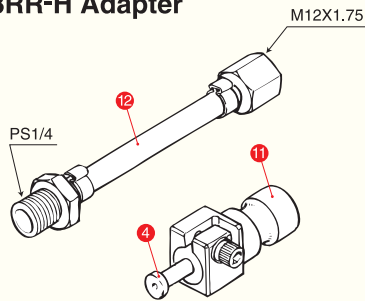

016081
308RR-N Adapter

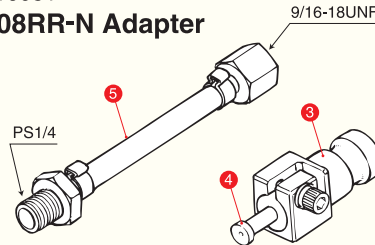

016083
308RR-B Adapter

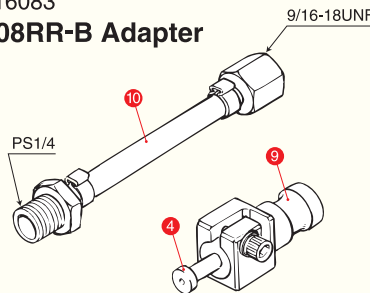

308RR Adapter Parts List

Reference No.	Parts No.	Parts Name
1	016085	308RR-T Adapter Fitting
2	016180	308RR-T Wire Guide Pin
3	016086	308RR-N Adapter Fitting
4	016181	308RR-N/B/H Guide Pin
5	016184	308RR-N Adapter Gas Hose
6	016087	308RR-D Adapter Fitting
7	023022	WT-64 Outlet Guide
8	023023	WT-64 Guide Adapter
9	016088	308RR-B Adapter Fitting
10	016185	308RR-B Adapter Gas Hose
11	016089	308RR-H Adapter Fitting
12	016186	308RR-H Adapter Gas Hose

308RR-N Adapter

021008
308RR-N-D Adapter

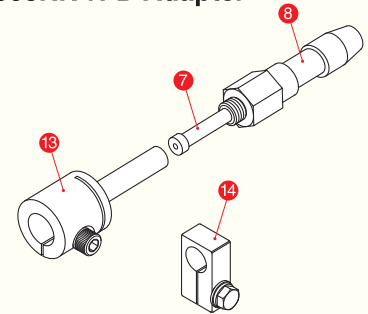

021010
308RR-N-DD Adapter

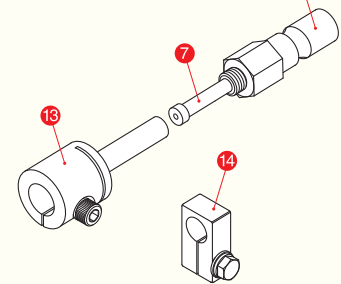

308RR-N Adapter Parts List

Reference No.	Parts No.	Parts Name
13	021013	N-D Adapter Fitting (w/o Tip Body)
14	023551	DSRC-3531 P/C Attachment
15	023024	CMRE741 Guide Adapter

Customized Torch Bodies

[Made-to-order]

We make customized torch bodies specifically designed to match your welding application. If you using a standard torch body length but cannot make satisfactory welds because the torch hits the workpiece, please consult us.

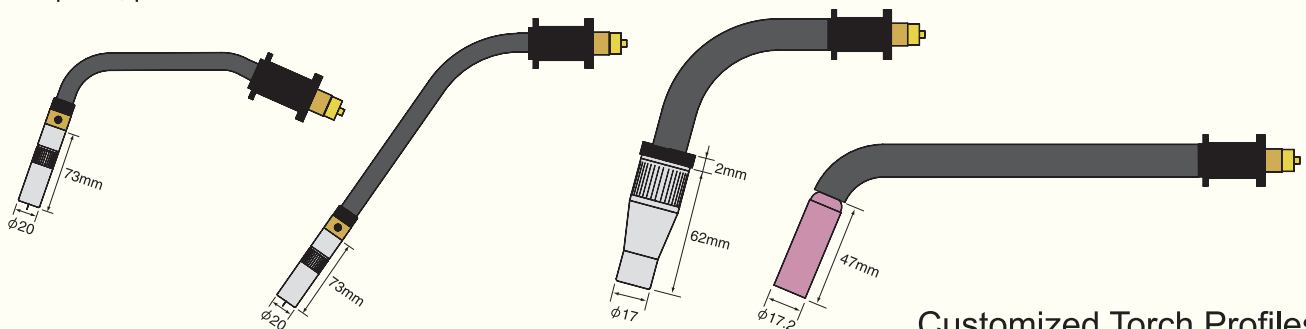

Customized Torch Profiles

Torch Type MA (with an internally mounted torch Cable) for Motoman MA1440

Note: The four types are the same in terms of performance. They differ in torch body length and whether they come with or without a shock sensor.

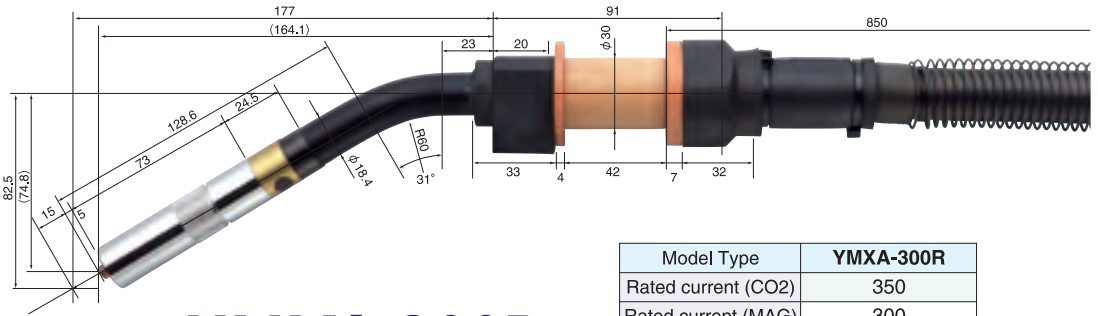

YMXA-300R

Without Shock Sensor

Model Type	YMXA-300R
Rated current (CO2)	350
Rated current (MAG)	300
Operation rate	60
Applicable wire size	0.8mm~1.2mm
Cooling method	air-cooled

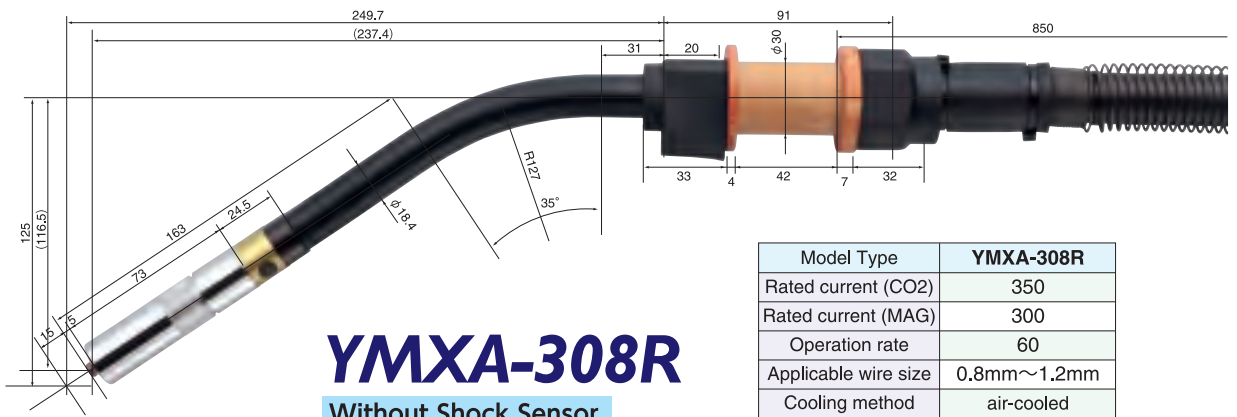

YMXA-308R

Without Shock Sensor

Model Type	YMXA-308R
Rated current (CO2)	350
Rated current (MAG)	300
Operation rate	60
Applicable wire size	0.8mm~1.2mm
Cooling method	air-cooled

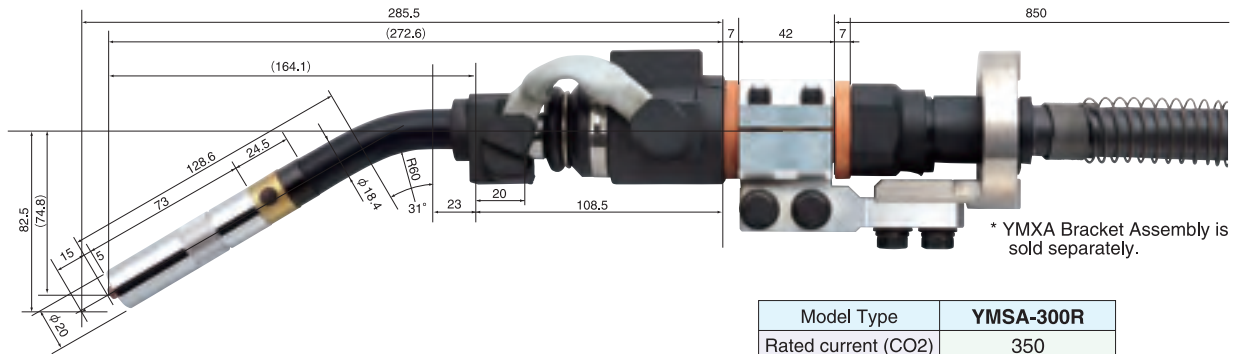

YMSA-300R

With Shock Sensor

Model Type	YMSA-300R
Rated current (CO2)	350
Rated current (MAG)	300
Operation rate	60
Applicable wire size	0.8mm~1.2mm
Cooling method	air-cooled

* YMXA Bracket Assembly is sold separately.



YMSA-308R

With Shock Sensor

Model Type	YMSA-308R
Rated current (CO2)	350
Rated current (MAG)	300
Operation rate	60
Applicable wire size	0.8mm~1.2mm
Cooling method	air-cooled

* YMXA Bracket Assembly is sold separately.

Type MH (with an externally mounted torch cable)
for Motoman MA1440

TK-308RR

Without Shock Sensor

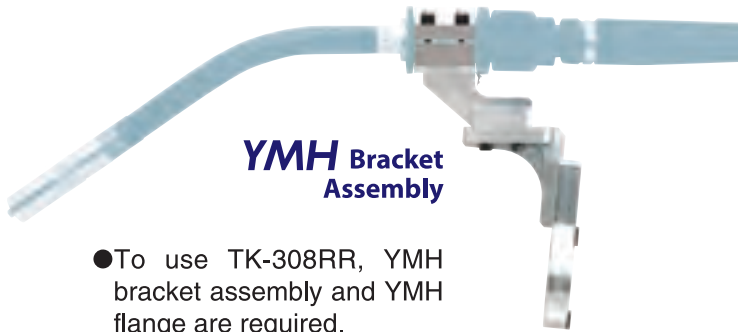

YMH Bracket Assembly

- To use TK-308RR, YMH bracket assembly and YMH flange are required.

SRCT-308R

With Shock Sensor

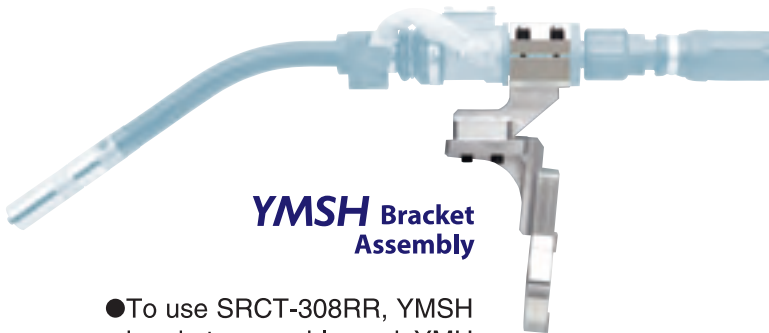

YMSH Bracket Assembly

- To use SRCT-308RR, YMSH bracket assembly and YMH flange are required.

YMH Bracket Assembly

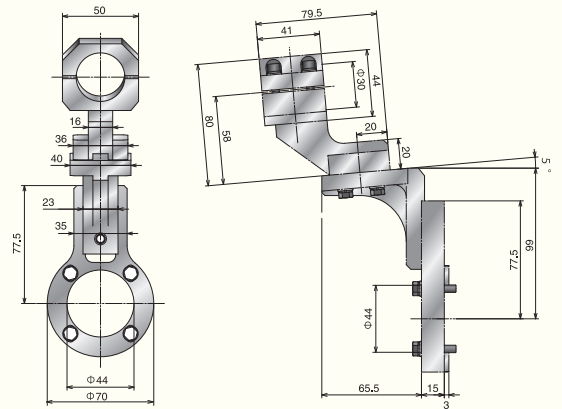

YMSH Bracket Assembly

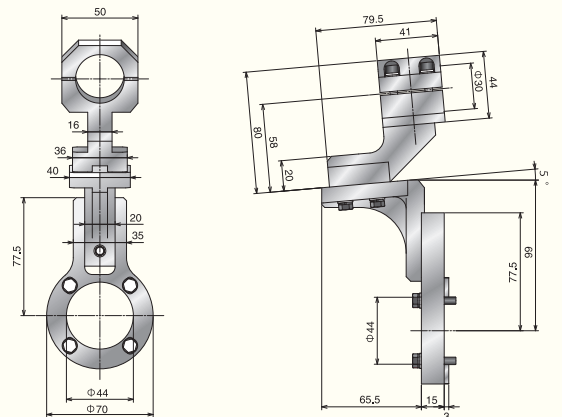

YMH Flange

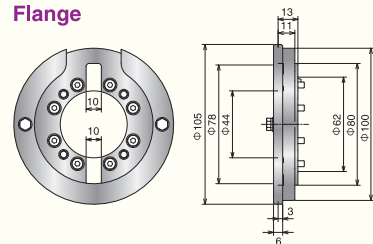

Type MA (with an internally mounted torch Cable)
for Motoman MA1440



YMXA Bracket Assembly +

- To use YMXA300R/ YMXA308R/ YMSA300R/ YMSA308R, YMXA bracket assembly is required.

YMA Flange

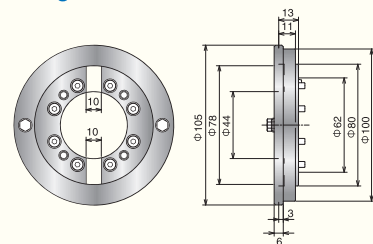

ACC Type Torch Body



- YMXA-300R**(ACC type)
- YMXA-308R**(ACC type)
- YMSA-300R**(ACC type)
- YMSA-308R**(ACC type)

ACC type is available for every torch.

MOTOMAN-EA Torches

YMENS-300R

YMENS-308R

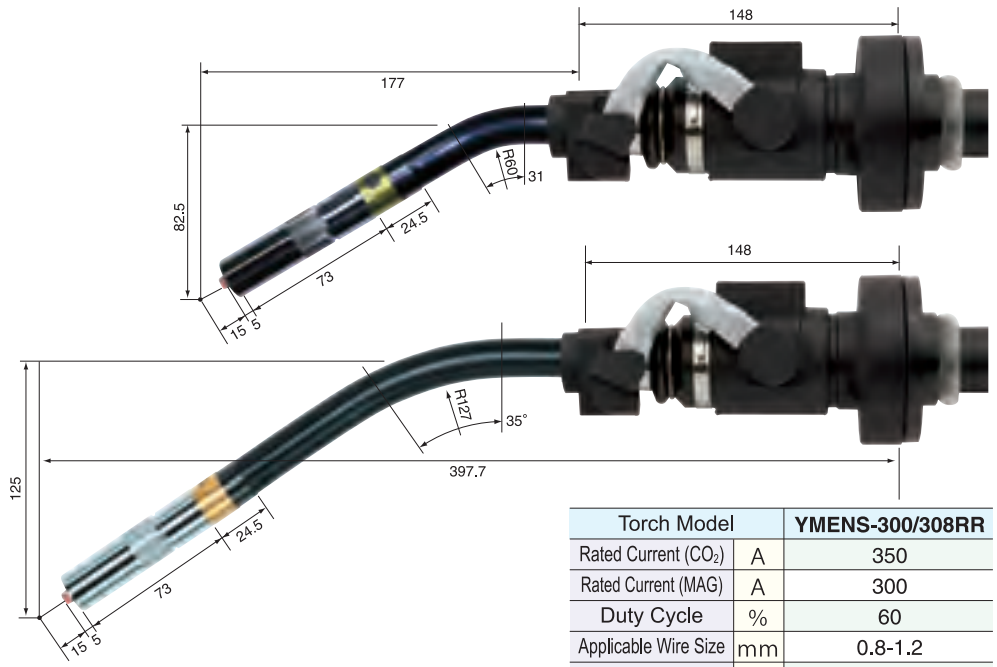

Torch Model	YMENS-300/308RR	
Rated Current (CO ₂)	A	350
Rated Current (MAG)	A	300
Duty Cycle	%	60
Applicable Wire Size	mm	0.8-1.2
Cooling Method		Air-Cooled

[Parts Drawings]

YMENS-300R/308R/ 500R/508R

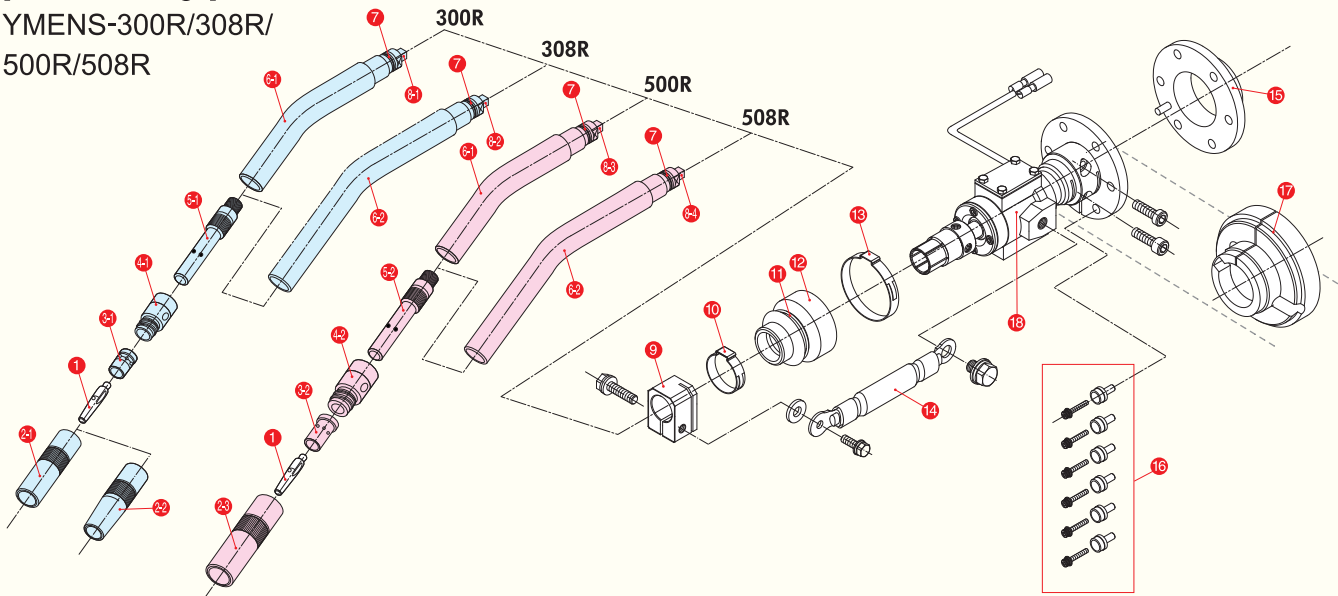

YMENS-300R/308R/500R/508R Parts List

Reference No.	Parts No.	Parts Name	Reference No.	Parts No.	Parts Name	Reference No.	Parts No.	Parts Name
1	002001	N Tip 0.9 mm	6-1,7	YEA003012	YMRS-300R/500R Torch Body (w/o Tip Body)	1~8	YEA005810	YMES-508R Torch Body Assy
	002002	N Tip 1.0 mm	6-2,7	3001043	YMES-308R/508R Torch Body (w/o Tip Body)	9	YEA000018	YSRC Clamp Block
	002003	N Tip 1.2 mm	7	Y0000FP10	O Ring F-P10	10	3001024	Hose Clamp 286-7R
	002017	N Tip 1.4 mm	5-1,6-1, 7	YEA003011	YMES-300R Torch Body (w/ Tip Body)	11	YM0980009	YMST-9800-09 Ring
	002004	N Tip 1.6 mm	5-1,6-2, 7	3001042	YMES-308R Torch Body (w/ Tip Body)	12	YM0980012	YMST-9800-12 Rubber Boot
2-1	001002	N Nozzle 16 mm	5-2,6-1, 7	YEA005011	YMES-500R Torch Body (w/ Tip Body)	13	3001025	Hose Clamp 455-7R
2-2	001003	N Nozzle 12 mm	5-2,6-2, 7	YEA005811	YMES-508R Torch Body (w/ Tip Body)	14	3001023	SRC Jumper Cable
2-3	001001	N Nozzle 19 mm	8-1	YEA003013	YMES-300R Inner Tube	15	YEA000014	YME Insulation Spacer
3-1	003002	N Orifice S	8-2	YEA003812	YMES-308R Inner Tube	16	YEA000015	YME Insulation Sleeve (with 6 sets of screws)
3-2	003001	N Orifice L	8-3	YEA005013	YMES-500R Inner Tube	17	YEA000017	YME Insulation Cover S
4-1	004002	N Insulator S	8-4	YEA005812	YMES-508R Inner Tube	9~18	YEA000020	T-Axis Unit Type S
4-2	004001	N Insulator L	1~8	YEA003010	YMES-300R Torch Body Assy			
5-1	016051	TK-308RRR Tip Body		YEA003810	YMES-308R Torch Body Assy			
5-2	016403	TK-508RRR Tip Body		YEA005010	YMES-500R Torch Body Assy			

YMENS-500R

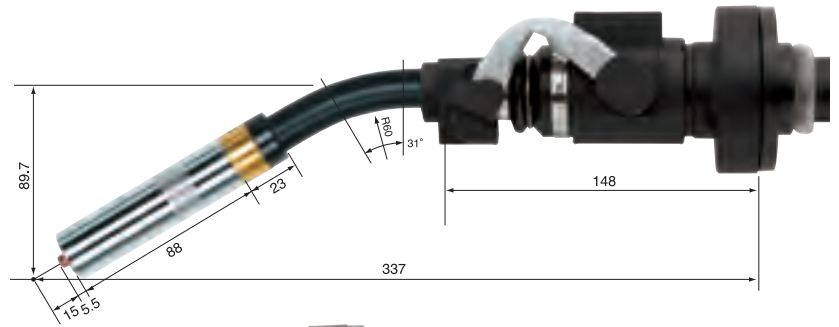

YMENS-508R

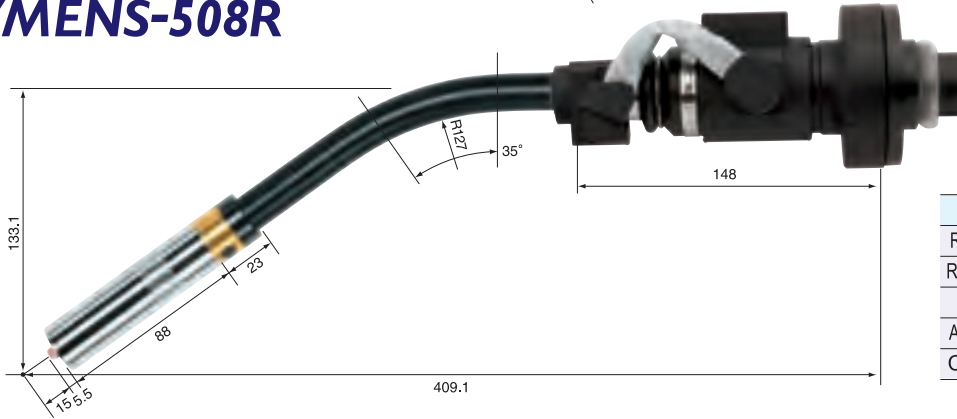

Torch Model	YMENS-500/508RR	
Rated Current (CO ₂)	A	500
Rated Current (MAG)	A	430
Duty Cycle	%	60
Applicable Wire Size	mm	1.2-1.6
Cooling Method		Air-Cooled

YMENS-500R WIRE CLAMP

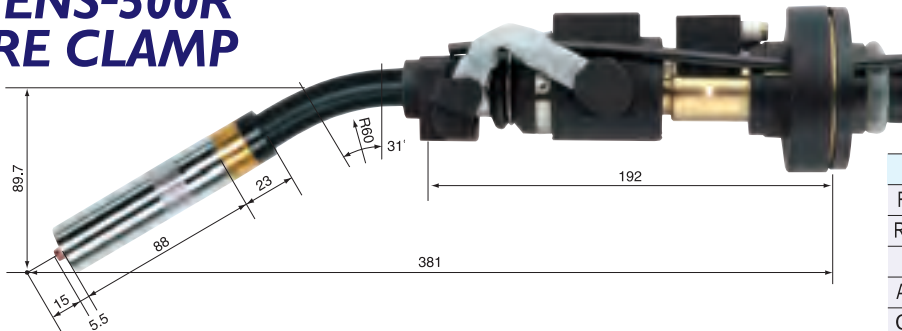

Torch Model	YMENS-500R	
Rated Current (CO ₂)	A	500
Rated Current (MAG)	A	430
Duty Cycle	%	60
Applicable Wire Size	mm	1.2-1.6
Cooling Method		Air-Cooled

Air-Cooled Torch for Aluminum Welding

YMENS-250RA

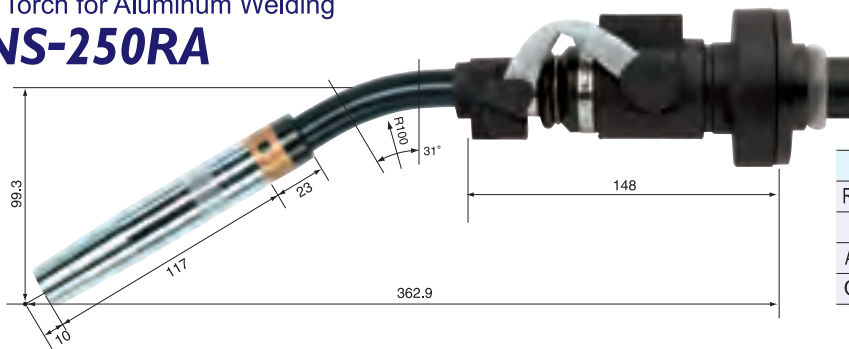

Torch Model	YMENS-250RA	
Rated Current (MAG)	A	250
Duty Cycle	%	60
Applicable Wire Size	mm	1.0-1.2
Cooling Method		Air-Cooled

YMENS-308R Long Torch Body (Made-to-order)

The torch body (straight section) of the YMENS-308RR is available in various lengths as shown in the drawing. We also accept special orders for fabricating original torch bodies in different lengths of your choice.

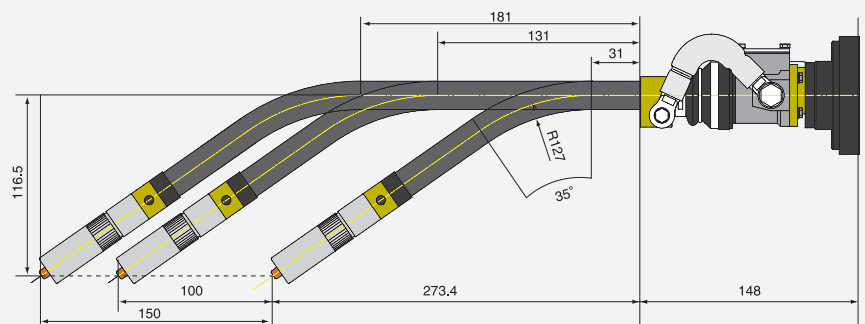

Parts No.	Parts Name
YEA003810	YMENS-308RR Torch Body Assy
YB0611170	YMENS-308RR Torch Body Assy (+100)
YB0307160	YMENS-308RR Torch Body Assy (+150)

YMHS Unit Assembly (Shock Sensor)

**Realizing high rigidity and high precision
A high strength,
high grade shock sensor optimal
for tough use environments**

Features

- 1** Detects shocks from all directions.
- 2** Despite its high rigidity, it is designed for optimal lost motion to alleviate torch deformation during impact and minimize damage to the robot.
- 3** Impact detection of interference objects is set to an optimal sensitivity level to protect the robot. As such, it does not impede the robot's normal movements such as during high-speed air cuts.
- 4** Due to its highly rigid and high precision nature, it offers high reproducibility, which shortens the recovery time following an impact.
- 5** Because the torch clamp portion has been changed, it can use torches of varying diameters, such as for air-cooled or water-cooled applications. (*1)
- 6** By replacing the flange portion, it can be used regardless of the type of robot. (*2)

*1 For use with a Tokin torch. (Ask us for more information in case of using other manufactures torch.)

*2 The standard specs are for the HP/MHt series robots made by Yaskawa Electric. To use it on a robot made by other manufacturers, contact us beforehand. (At times, it might no be possible to mount it on a robot made by other manufacturers.)

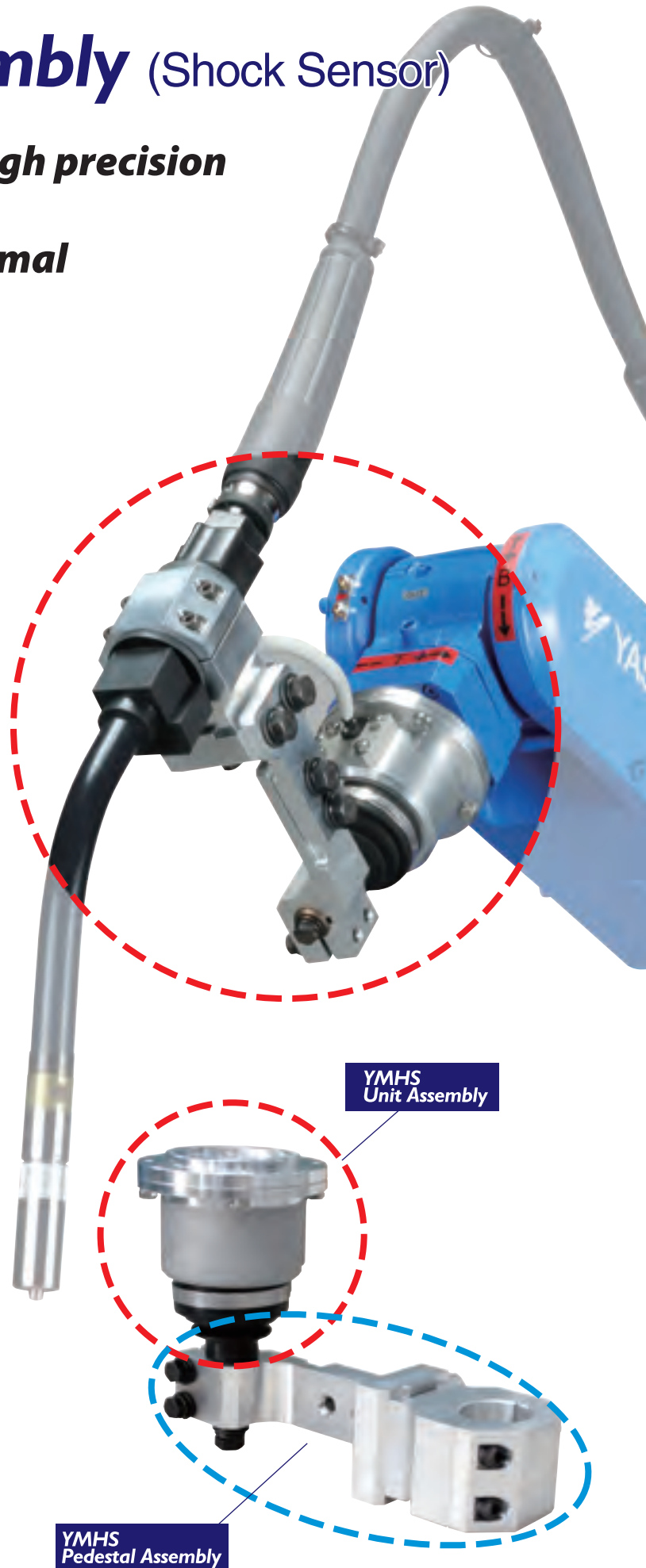

YMHS Unit Assembly + Plus YMHS Pedestal Assembly

Use YMHS unit assembly and pedestal assembly in combination.

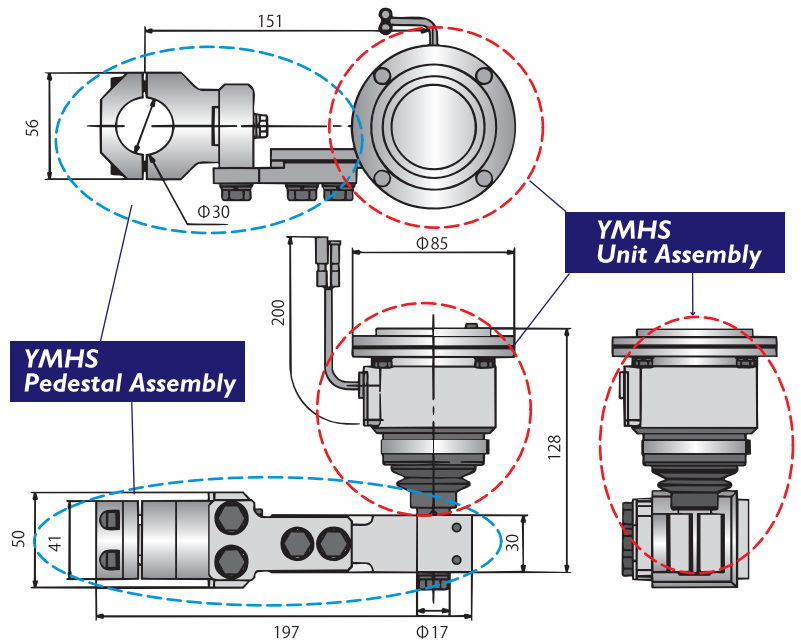

YMHS Unit Assembly

Parts No. YMHS00001 Weight: 900g

The standard specs are for the HP/MHt series robots made by Yaskawa Motoman

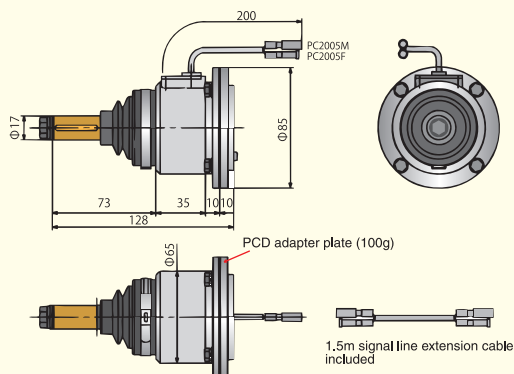

With an applicable Flange, YMHS Unit Assembly can be used for other robots. (Ask us for more information in case of using other robots.)

YMHS Pedestal Assembly

Parts No. YMHS00005 Weight: 620g

For YMHS Pedestal Assembly (MH6 $\Phi 30$)

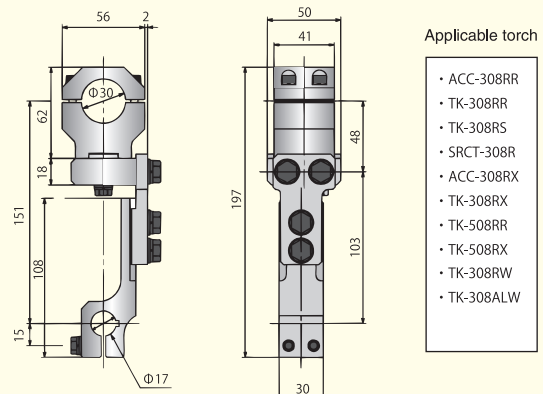

Applicable torch

- ACC-308RR
- TK-308RR
- TK-308RS
- SRCT-308R
- ACC-308RX
- TK-308RX
- TK-508RR
- TK-508RX
- TK-308RW
- TK-308ALW

This pedestal is for attaching a 308 series Tokin torch. A torch measuring $\Phi 30$ at the clamp can be attached.

Option

YMHS-308R Alignment Fixture

Parts No. YJ1002180



Gauge dedicated to adjust the Tool Center Point when replacing the torch.

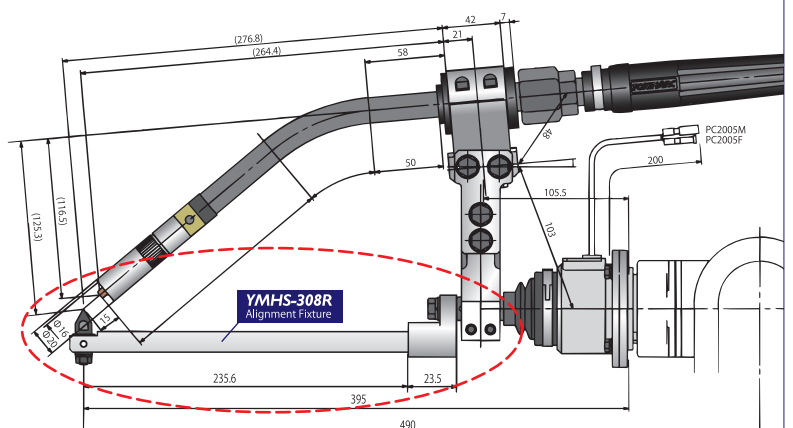

DSRC-353 I

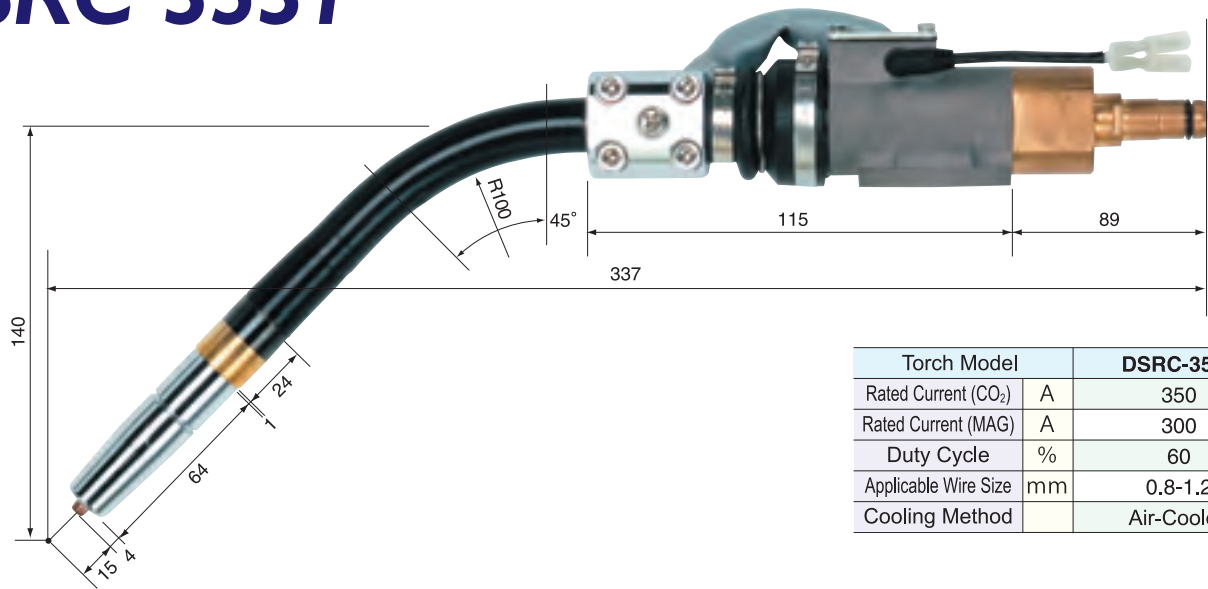

Torch Model		DSRC-3531
Rated Current (CO ₂)	A	350
Rated Current (MAG)	A	300
Duty Cycle	%	60
Applicable Wire Size	mm	0.8-1.2
Cooling Method		Air-Cooled

[Parts Drawings] DSRC-3531

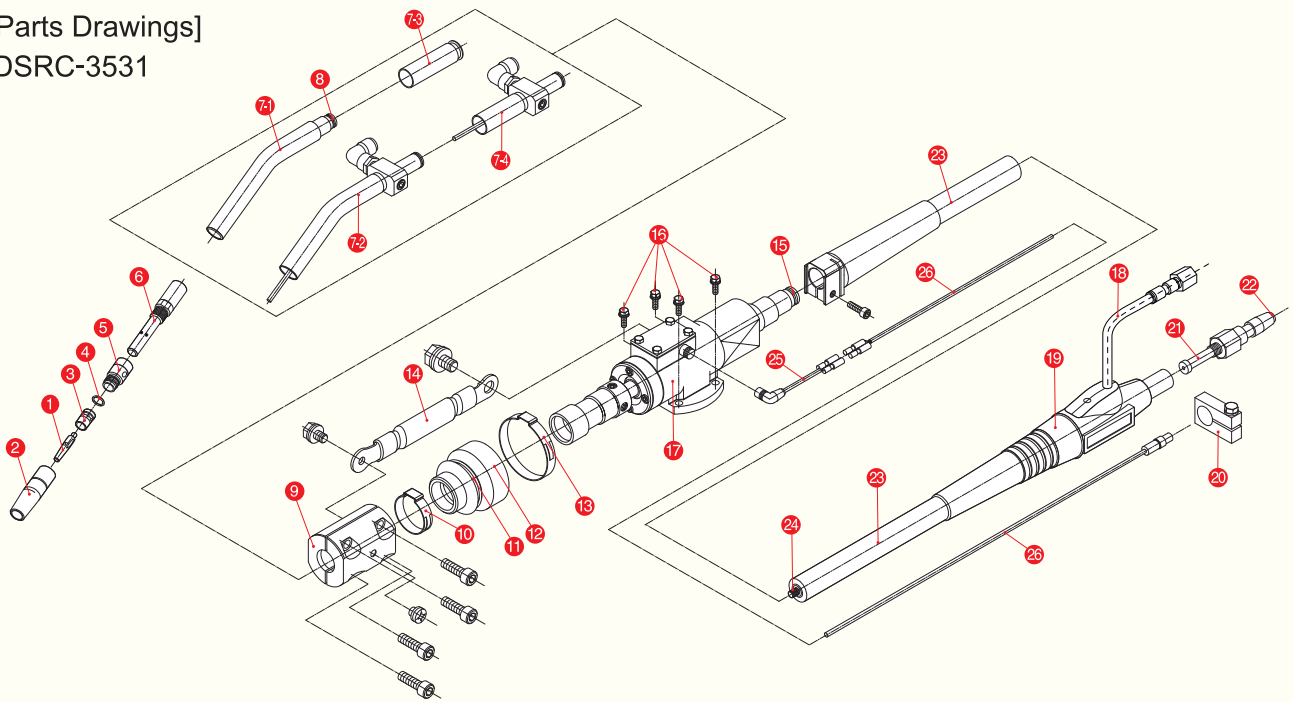

DSRC-3531 Parts List

Reference No.	Parts No.	Parts Name	Reference No.	Parts No.	Parts Name	Reference No.	Parts No.	Parts Name
1~26	023581	DSRC-3531-1.1	1~8	023506	DSRC-3531 Torch Body Assy	18~24	023511	DSRC-3531-1.1 P/C
*	∩	∩	9	023508	DSRC Clamp Block	*	∩	∩
	023589	DSRC-3531-2.5	10	3001024	Hose Clamp 286-7R		023519	DSRC-3531-2.5 P/C
1	023008	D Tip 0.9 mm	11	YM0980009	YMST-9800-09 Ring	24	023531	DSRC Liner 1.1 m
	023009	D Tip 1.0 mm	12	YM0980012	YMST-9800-12 Rubber Boot	*	∩	∩
	023010	D Tip 1.2 mm	13	3001025	Hose Clamp 455-7R		023539	DSRC Liner 2.5 m
2	023501	DSRC Nozzle	14	023509	DSR Junper Cable	18~26	023521	DSRC-3531-1.1 PC ASSY
3	023014	D Orifice S	15	Y0000FP10	O Ring F-P10	*	∩	∩
4	023502	DSRC-3531 Spring Washer	16		Hexagon Bolt x4 (M5 x 25)		023529	DSRC-3531-2.5 PC ASSY
5	023015	D Insulator S	9~17	023500	DSRC Sensor Unit Assy	25	3001039	YSRC Molded Cable
6	023503	DSRC-3531 Tip Body	1~17	023507	DSRC-3531 Torch Assy	26	023571	DSRC Extension Cable 1.1 m
7-1,8	023504	DSRC-3531 Torch Body (w/o Tip Body)	18	033701	N Gas Hose (with Push-In Air Fitting)	*	∩	∩
7-2,8	023554	DSRCB-3531 Torch Body (w/o Tip Body)	19	033108	Robotic Torch Cable Supporter		023579	DSRC Extension Cable 2.5 m
7-3,8	023552	DSR-3531 Torch Body (w/o Tip Body)	20	023551	DSRC-3531 P/C Attachment	25~26	023561	DSRC Shock Sensor Cable 1.1 m
7-4,8	023553	DSRB-3531 Torch Body (w/o Tip Body)	21	023022	WT-64 Outlet Guide	*	∩	∩
8	023505	DSRC Torch Body O Ring	22	023023	WT-64 Guide Adapter		023569	DSRC Shock Sensor Cable 2.5 m

*Available in 1.1 m, 1.2 m, 1.3 m, 1.4 m, 1.5 m, 1.6 m, 1.8 m, 2.1 m, and 2.5 meter lengths.

ROBOT PERIPHERALS

APC - AUTO PARTS CHANGER

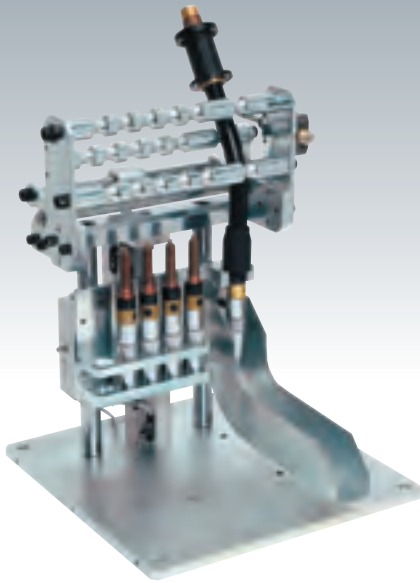

Consumable parts unit (from tip to tip body) can be replaced by a single touch operation without production downtime.

NOZZLE CLEANER

046200



Simply connect the air tube to operate. Cleaning heads are available in various sizes for sizing of nozzles.

WIRE CUTTER

046250



Wire Cutter is driven by air pressure. The cutting blade is designed by principle of leverage and made of high durable material. One side of a blade can cut more than 40,000 times. (Cutting blade can be used on both sides.)

AIR BLOW UNIT

016701



Designed for spatter removal of inside of nozzles and cooling effect of nozzles and tips. The unit can be mounted on existing torches listed below.

(TK-308RR/ACC-308RR/ACC-352/RT352/RR308Y/DT-RA/MAN-308RR)

WIRE CLAMP UNIT

017100

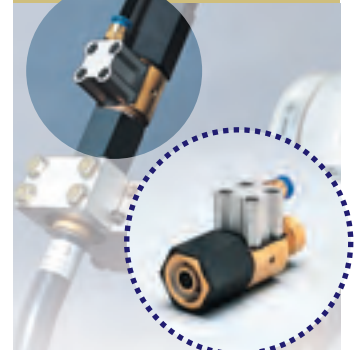

Wire Clamp Unit retains the wire stick-out for accurate touch sensing. The unit can be mounted on existing torches listed below.

(TK-308RR/ACC-308RR/ACC-352/RT352/RR308Y/DT-RA/MAN-308RR)

FLEXIBLE CONDUIT CABLES

▼ N/D Flexible Conduits

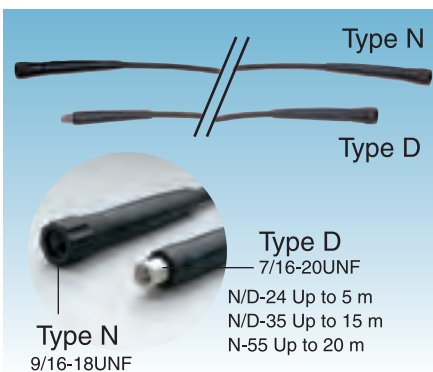

▼ Simplified Flexible Conduit

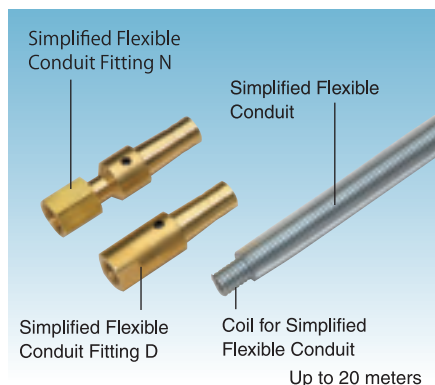

▼ Teflon® Flexible Conduit

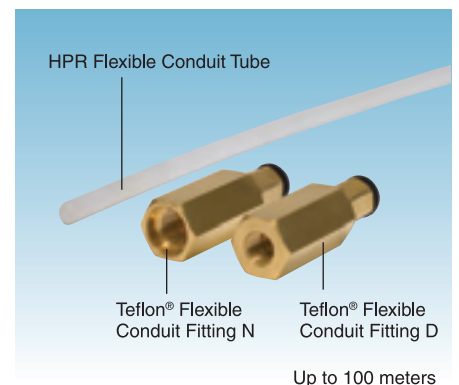



Product Catalogue



Semi-Automatic Torches



Water-Cooled
 Robotic Torches



TIG Welding Torches



Replacement Parts



Robotic Peripherals

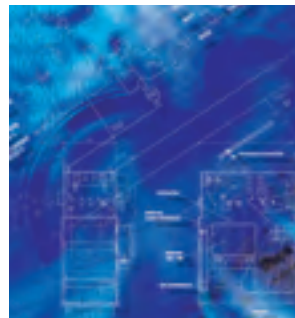

Fume Extractors



Plasma Parts,
 Laser Parts & Optics

▼ Please contact us by FAX or E-mail for catalogues that interest you.
 You can also download them from our website.

FAX
+81-53-485-5680

E-mail
trading@tokinarc.co.jp

URL
http://www.tokinarc.co.jp

TOKIN CORPORATION

**1509 Okubo-cho, Nishi-ku, Hamamatsu-shi,
 Shizuoka Japan 432-8006**

TEL : +81-53-485-5252 FAX : +81-53-485-5680
 E-mail trading@tokinarc.co.jp
 URL http://www.tokinarc.co.jp

Suzhou Tokin Machine & Metal Corporation

No.107 Dong Cang North Road, Economic Development Zone,
 Tai cang city, Jiang su China,

TEL : (010)86-512-53569095
 FAX : (010)86-512-53577726
 Email : sales@tokinarc.com.cn
 Website : http://www.tokinarc.com

For more information, contact us at

Parts specifications, dimensions and design may be changed without prior notice for the purpose of parts improvement. The parts color shown here is a printed image and the actual color might vary somewhat.